



HOPE

design Francisco Gomez Paz / Paolo Rizzato

**LUC
PLAN**

HOPE

design Francisco Gomez Paz / Paolo Rizzatto

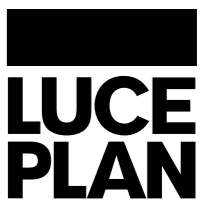



HOPE

design Francisco Gomez Paz / Paolo Rizzato

🇺🇸 Inspired by nature, but with technical innovation which combine to create the magic of Hope, a modular lamp that is both elegant and versatile in its contemporary interpretation of the traditional crystal chandelier, which evokes a similar aesthetic, but with a notable reduction in its environmental impact.

🇮🇹 L'ispirazione organica e l'innovazione tecnologica concorrono a definire il fascino di Hope, una lampada componibile e modulare, versatile ed elegante, che rivisita in chiave contemporanea l'antica tradizione del lampadario in cristallo, riproponendone lo spettacolo estetico con una sensibile riduzione dell'impatto ambientale.

🇩🇪 Organische Inspiration und technologische Innovation bilden einen Teil der Faszination, die Hope ausstrahlt. Eine kombinierbare, modulare Leuchte, vielseitig und elegant. Kristalllustertradition vergangener Zeiten zeitgemäß chiffriert. Dasselbe beeindruckende ästhetische Schauspiel – nur mit deutlich weniger Platzanspruch.

🇫🇷 L'inspiration organique et l'innovation technologique contribuent à définir le charme de la Hope, une lampe composable et modulaire, versatile et élégante, qui revisite de façon contemporaine le concept du lustre en cristal traditionnel pour en representer les qualités esthétiques avec une réduction sensible de son impact sur l'environnement.

🇪🇸 La característica fascinante de Hope es su inspiración orgánica y la innovación tecnológica aplicada. Se trata de una lámpara componible y modular, versátil y elegante, que reinterpreta en clave contemporánea la antigua tradición de las lámparas de techo de cristal, donde de nuevo destaca el espectáculo estético con una sensible reducción del impacto medioambiental.

Dimensions

floor
h 72.4"
Ø 20"

ceiling
h 16.5"
Ø 27.2"

wall
h 19.3" - 124"
projection 18"

suspension
h 19.3 - 21.2" - 26" - 35.4"
Ø 24" - 28.2" - 43" - 79"

Materials

structure in polished stainless steel and transparent polycarbonate;
transparent polycarbonate prismatic lenses

Structure finishes

polished and transparent

Fresnel lens finishes

transparent

Lamps

max 150W incandescent
max 150W halogen
23/32/42W halogen energy saver





🇺🇸 Rationalisation of materials and a visual lightness were the inspiration in creating Hope. It's polycarbonate petals are actually formed by Fresnel lenses that optimise reflection and refraction which enhance the luminous effect, but reduce energy consumption.

🇮🇹 Smaterializzazione e leggerezza sono le cifre progettuali che hanno guidato la realizzazione di Hope. I suoi "petali" in policarbonato sono, in realtà, lenti Fresnel piane, dotate di eccellenti proprietà riflettenti e rifrattive, in grado di amplificarne il suggestivo effetto luminoso e ridurre il consumo energetico.

🇩🇪 Aufhebung materieller Schwere und Leichtigkeit waren die richtungsweisenden Projektvorgaben bei der Realisierung von Hope. Ihre Blütenblätter aus Polycarbonat sind in Wirklichkeit flache Fresnel-Linsen mit einem außerordentlichen Reflexions- und Lichtbrechungsvermögen, das den faszinierende Effekt des Lichts verstärkt und den Energieverbrauch reduziert.

🇫🇷 Dématérialisation et légèreté sont les concepts du projet qui a porté à la réalisation de la Hope. Ses 'pétales' en polycarbonate sont, en réalité, des lentilles de Fresnel planes, dotées d'excellentes propriétés réfléchissantes et réfractives, en mesure d'amplifier la suggestion de l'effet lumineux et de réduire la consommation d'énergie.

🇪🇸 Desmaterialización y ligereza son las claves de proyecto que han caracterizado la realización de Hope. Sus 'pétalos' de policarbonato son, en realidad, lentes Fresnel planas, dotadas de excelentes propiedades reflectantes y refractivas, capaces de amplificar el suggestivo efecto luminoso y de reducir el consumo de energía.

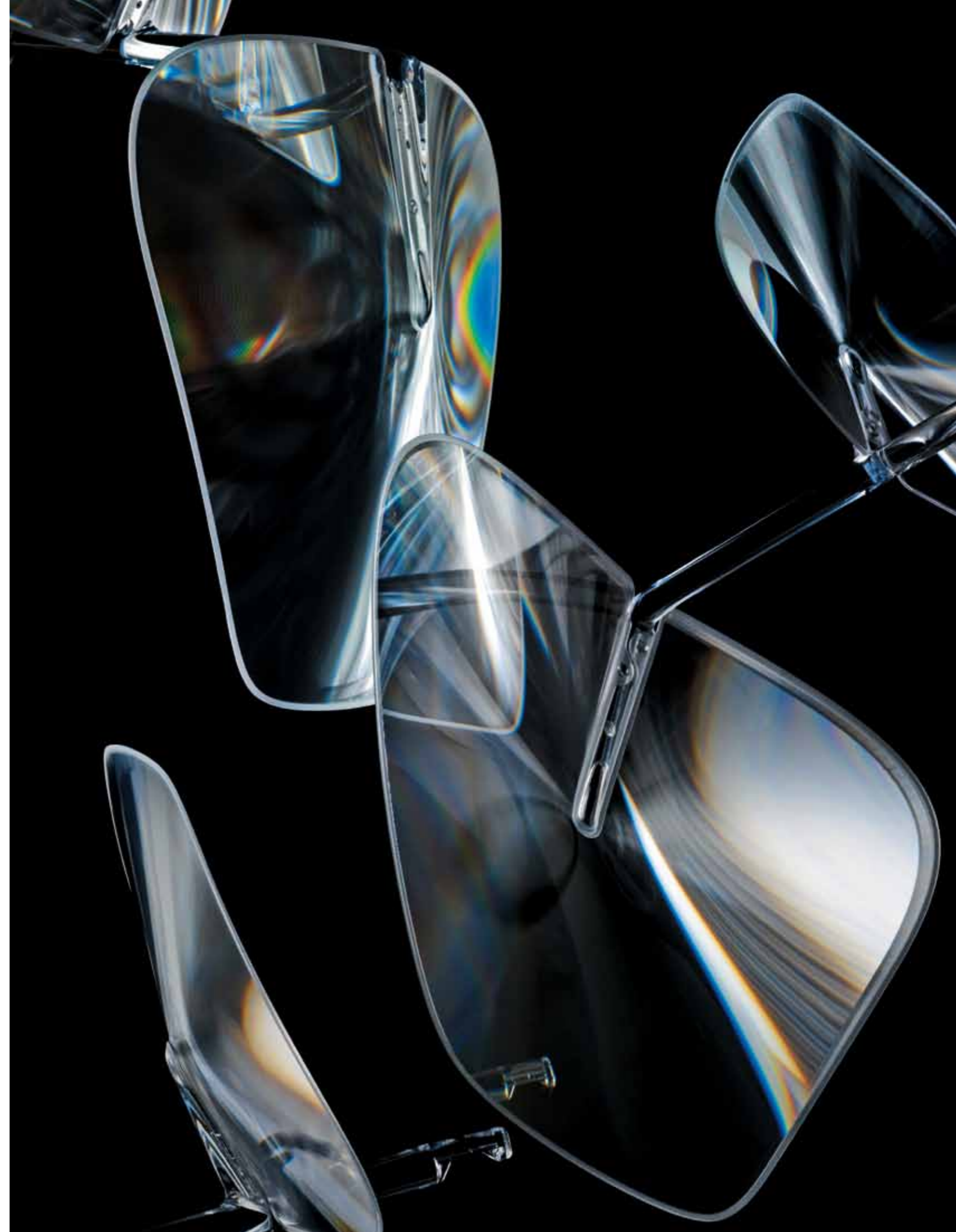
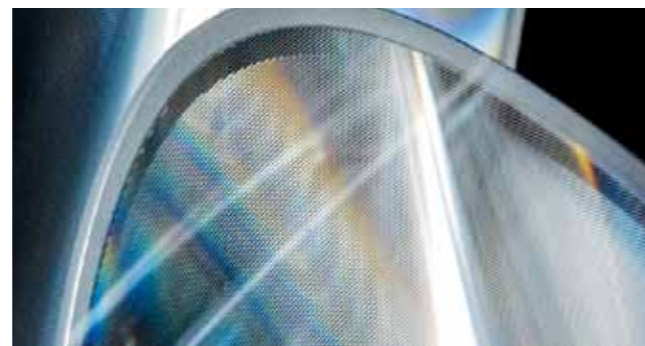
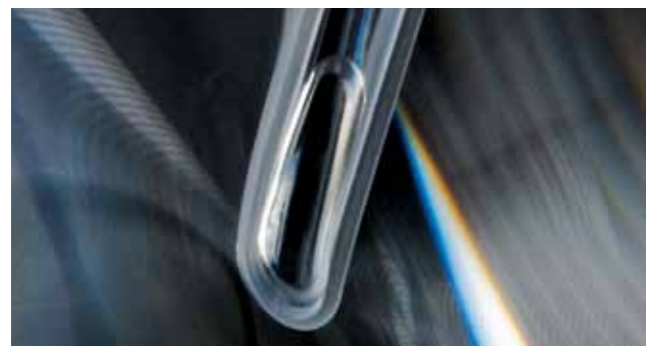



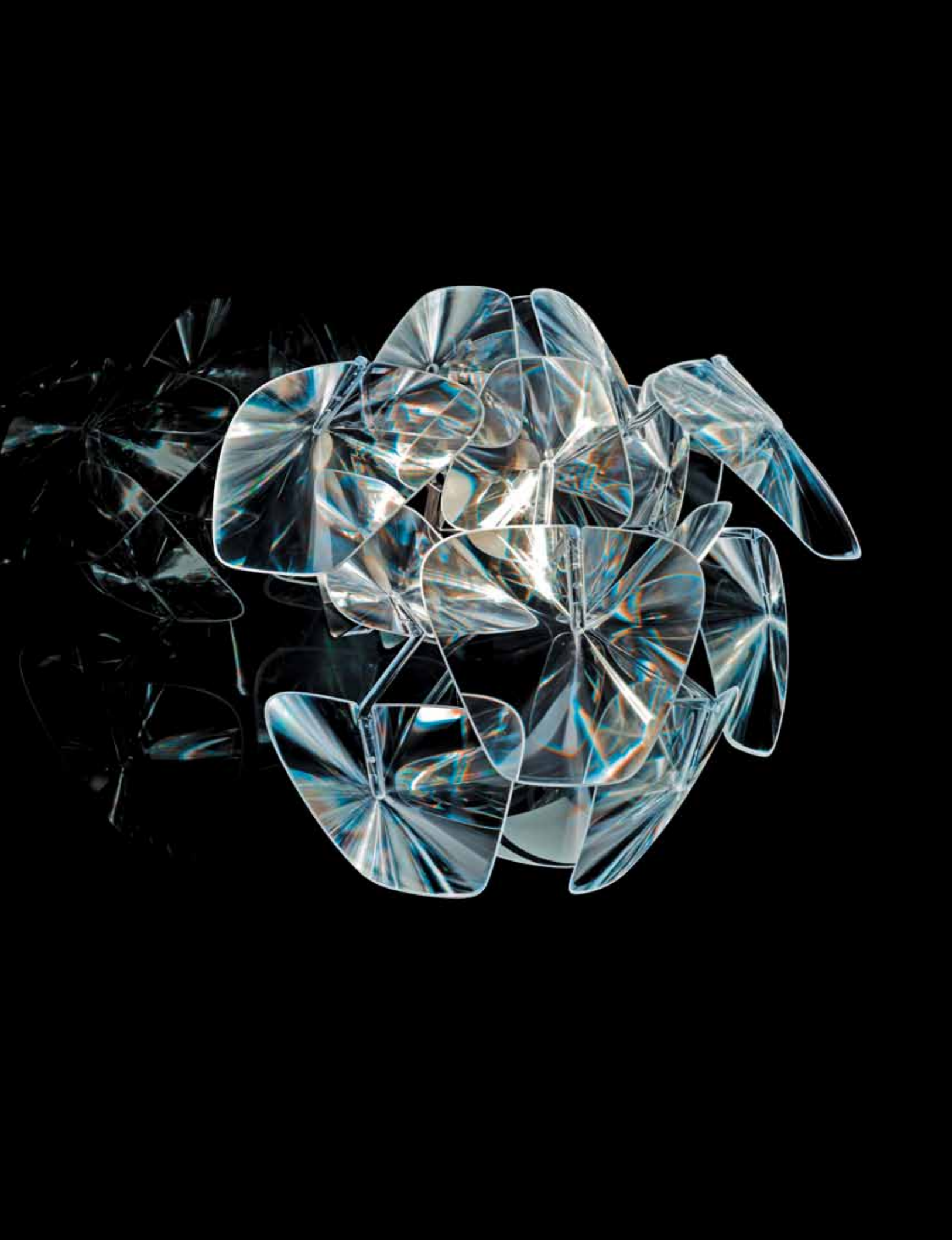



🇺🇸 The Hope family includes floor, wall, ceiling and hanging versions. A simple assembly kit for the hanging lamps, available in different sizes, offer a wide variety of configurations which can be personalised with overlapping compositions that will enhance any space.

🇮🇹 La famiglia di lampade Hope si declina in modelli da terra, da parete, da soffitto e a sospensione. Grazie a un pratico kit di montaggio, la versione a sospensione, proposta in diverse misure, offre inoltre un'ampia possibilità di configurazioni, personalizzabili secondo composizioni sovrapposte in grado di valorizzare ogni tipo di spazio.



🇫🇷 La famille de la Hope se décline en modèle au sol, muraux, de plafond et à suspension. Grâce à un kit de montage pratique, la version à suspension, proposée en plusieurs mesures, offre par ailleurs une vaste variété de configurations, personnalisables selon des compositions superposées en mesure de valoriser toutes les typologies d'espace.

🇩🇪 Die Lampenfamilie Hope besteht aus Boden-, Wand-, Decken- und Pendelleuchten. Dank eines praktischen Montagesets bietet die in verschiedene Größen erhältliche Pendelleuchte zahlreiche Möglichkeiten. Die Leuchtenarme lassen sich in Stufen individuell konfigurieren, sodass sich jeder beliebige Raum aufwerten lässt.

🇪🇸 La familia de lámparas Hope se declina en modelos de pie, pared, techo y suspensión. Gracias a un práctico kit de montaje, la versión de suspensión, propuesta en diversas medidas, ofrece además una amplia posibilidad de configuraciones, que pueden personalizarse según composiciones superpuestas que consiguen valorizar todo tipo de espacios.

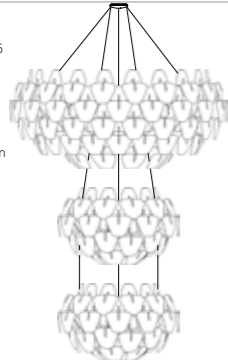
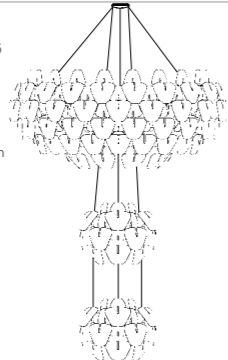
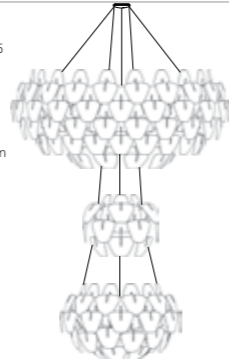
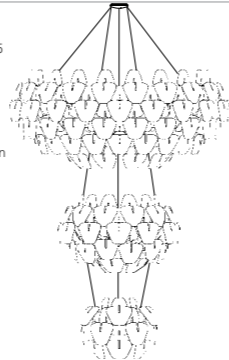
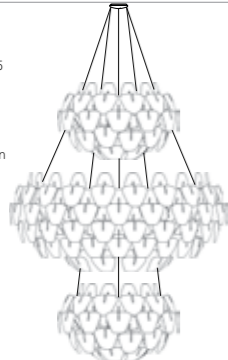
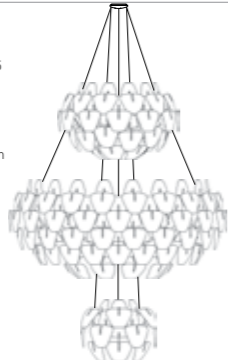
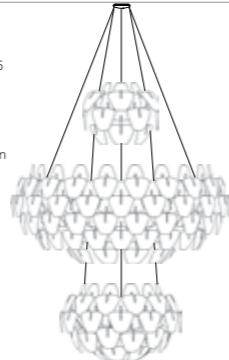
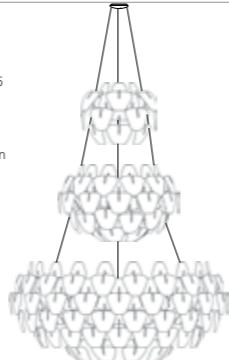
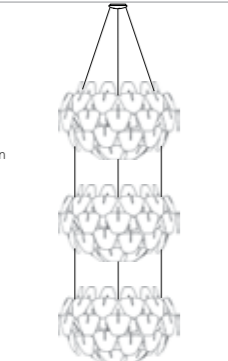
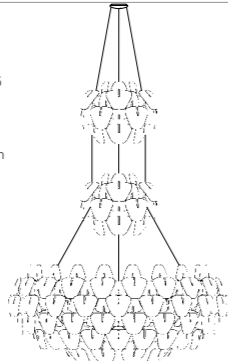
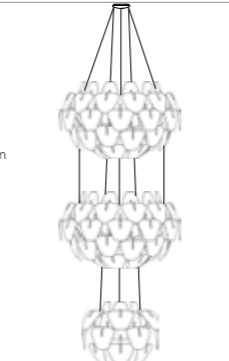
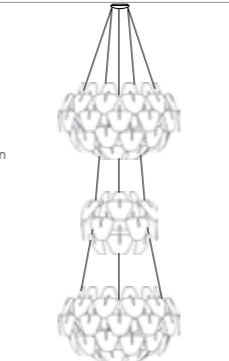
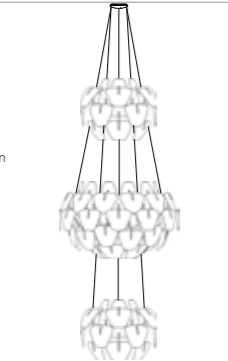
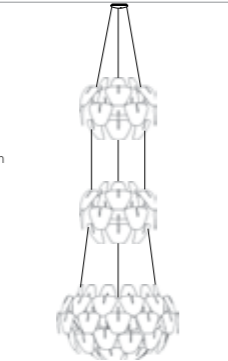
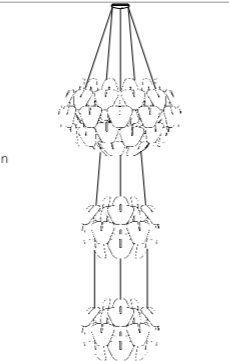

D66 composition kits

<p>A</p> <p>D66/105 D66/42 D66/42</p> <p>H tot min 157.5"</p> <p>weight 70.5 lb</p> 	<p>B</p> <p>D66/105 D66/18 D66/18</p> <p>H tot min 143"</p> <p>weight 50.7 lb</p> 	<p>C</p> <p>D66/105 D66/18 D66/42</p> <p>H tot min 143.3"</p> <p>weight 50.7 lb</p> 	<p>D</p> <p>D66/105 D66/42 D66/18</p> <p>H tot min 147.2"</p> <p>weight 60.6 lb</p> 
<p>E</p> <p>D66/42 D66/105 D66/42</p> <p>H tot min 127.9"</p> <p>weight 70.5 lb</p> 	<p>F</p> <p>D66/42 D66/105 D66/18</p> <p>H tot min 117.7"</p> <p>weight 60.6 lb</p> 	<p>G</p> <p>D66/18 D66/105 D66/42</p> <p>H tot min 127.6"</p> <p>weight 60.6 lb</p> 	<p>H</p> <p>D66/18 D66/42 D66/105</p> <p>H tot min 98"</p> <p>weight 60.6 lb</p> 
<p>I</p> <p>D66/42 D66/42 D66/42</p> <p>H tot min 96.5"</p> <p>weight 46.3 lb</p> 	<p>L</p> <p>D66/18 D66/18 D66/105</p> <p>H tot min 119.3"</p> <p>weight 50.7 lb</p> 	<p>M</p> <p>D66/42 D66/42 D66/18</p> <p>H tot min 90"</p> <p>weight 36.4 lb</p> 	<p>N</p> <p>D66/42 D66/18 D66/42</p> <p>H tot min 86.2"</p> <p>weight 36.4 lb</p> 
<p>P</p> <p>D66/18 D66/42 D66/18</p> <p>H tot min 78"</p> <p>weight 26.5 lb</p> 	<p>Q</p> <p>D66/18 D66/18 D66/42</p> <p>H tot min 78"</p> <p>weight 26.5 lb</p> 	<p>R</p> <p>D66/42 D66/18 D66/18</p> <p>H tot min 83.8"</p> <p>weight 26.5 lb</p> 	



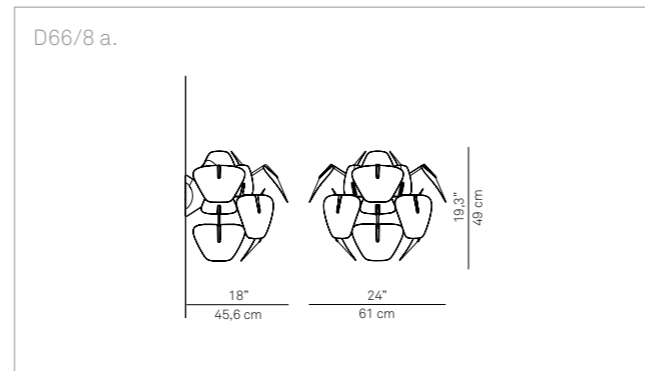
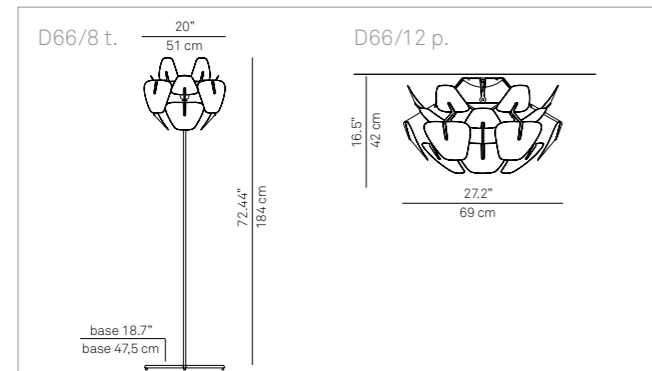
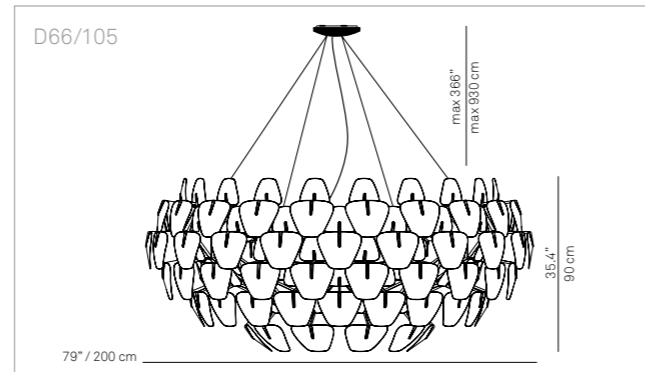
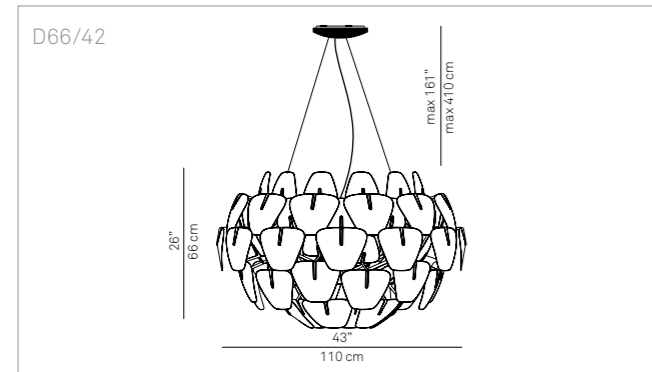
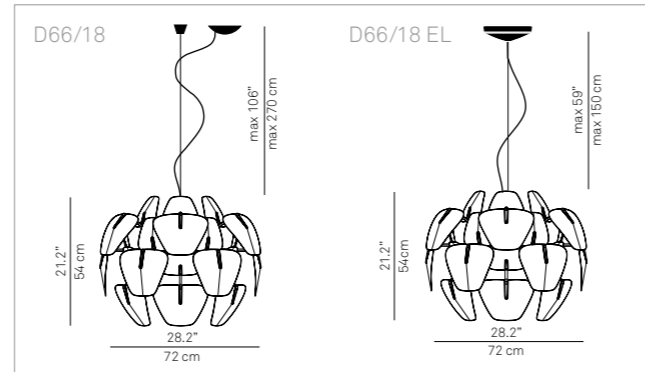
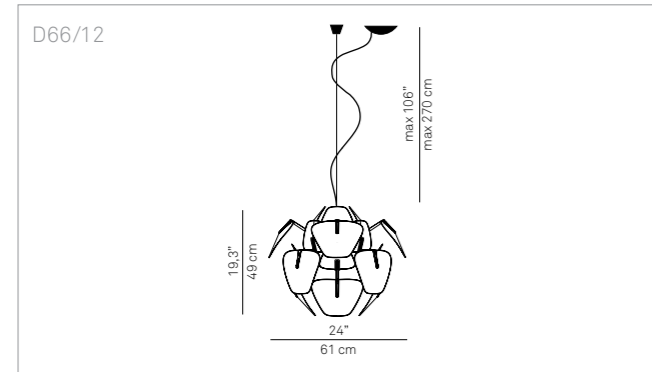

Materials
 structure in polished stainless steel and transparent polycarbonate arms
 transparent polycarbonate prismatic lenses

Structure finishes
 polished and transparent

Lens finishes
 transparent

Note
 D66/42 and D66/12p requires 3 bulbs; D66/105 requires 5 bulbs

Lamp		D66/18 EL	D66/12p
D66/8a - D66/8t - D66/12	D66/18 - D66/42 - D66/105		
150W A-21 med. base	150W T-10 halogen shielded med. base	23/32/42W CFEL GX24q-3/4 (120-277V-)	150W A-21 med. base
23W CFEL med. base			150W T-10 halogen shielded med. base
			23W CFEL med. base



© 2011 by Luceplan spa, Milano
 All rights reserved.

Project Coordination
 Patrizia Vicenzi with Rosi Guadagno

Art Direction
 RADL Milano

Texts
 © Francesco Massoni

Photos
 Santi Caleca
 Tom Vack
 Egon Gade

Printed in Italy
 GECA SpA, Milano
 April 2011

Luceplan reserves the right to introduce any change to its own models without prior notice.

The logo consists of the word "LUCEPLAN" in a bold, white, sans-serif font. Above the text is a white rectangular bar. The background of the entire page is a complex, abstract pattern of overlapping, faceted shapes that resemble cut glass or crystals, creating a vibrant, multi-colored iridescent effect.

LUCEPLAN HEADQUARTER

Via E.T. Moneta, 40
20161 Milano
T +39 02 66 242 1
F +39 02 66 203 400
N. verde 800 800 169
info@luceplan.com

LUCEPLAN USA

26 Broadway
NY 10004 New York
T +1 212 98 96 265
F +1 212 46 24 349
info@luceplanusa.com

LUCEPLAN BELGIUM

Modular Lighting Instruments
Armoedestraat 71
8800 Roeselare
T +32 (0) 51 26 56 56
F +32 (0) 51 22 80 04
welcome@supermodular.com

LUCEPLAN FRANCE

225 Rue du Faubourg
Saint-Honoré
75008 Paris
T +33 1 44 83 92 87
F +33 1 44 83 92 88
luceplan_fr@luceplan.com

LUCEPLAN GERMANY

Prenzlauer Allee 39
D-10405 Berlin
Tel. +49 30 44 33 84 0
Fax +49 30 44 33 84 22
luceplan_de@luceplan.com

LUCEPLAN NETHERLANDS

Modular Lighting Nederland
Bouwerij 54
1185 XX Amstelveen
T +31 (0) 20 347 30 47
F +31 (0) 20 347 30 48
info@modular.nl

LUCEPLAN RUSSIA

Modular Lighting Instruments
(Representation)
Mr. Rudy Van Hoof
Moscow
T +7 919 991 30 73
rudyvanhoof@supermodular.com

LUCEPLAN SCANDINAVIA

Klubiensvej 22
Pakhus 48 - Frihavnen
DK 2100 Copenhagen
T +45 36 13 21 00
F +45 36 13 21 01
info@luceplan.net

LUCEPLAN STORES

MILANO

Corso Monforte 7
20122 Milano
Tel. +39 02 76 015 760
Fax +39 02 78 4062
luceplanstore@luceplan.com

NEW YORK

49 Greene Street
NY 10013 New York
Tel. +1 212 966 1399
Fax +1 212 966 1799
info@luceplanusa.com

PARIS

225 Rue du Faubourg
Saint-Honoré
75008 Paris
T +33 1 44 83 92 87
F +33 1 44 83 92 88
luceplan_fr@luceplan.com

www.luceplan.com